

APPENDIX G2

Trussel Technologies Inc. Technical Memorandum, Response to CalAm MPWSP DEIR

This page intentionally left blank



Technical Memorandum
Response to Comment on CalAm MPWSP DEIR

Date: November 29, 2016

To: Environmental Science Associates
Eric Zigas

CC: California American Water
Ian Crooks

Prepared by: Trussell Technologies, Inc.
Anya Kaufmann
Rhodes Trussell, Ph.D., P.E., BCEE

Reviewed by: Trussell Technologies, Inc.
John Kenny, P.E.
Céline Trussell, P.E., BCEE

Subject: Response to comment from William Bourcier on CalAm Monterey Peninsula Water Supply Project; Draft Environmental Impact Report

1 INTRODUCTION

On September 30, 2015, a private citizen, William Bourcier, submitted a comment on the April 2015 Draft Environmental Impact Report (DEIR) for the Monterey Peninsula Water Supply Project (MPWSP) prepared by Environmental Science Associates (ESA) on behalf of the California Public Utilities Commission. Mr. Bourcier expressed concerns about the release of greenhouse gases (GHG) from feed water sourced from subsurface intakes. Trussell Technologies was retained to evaluate the GHG releases anticipated from the groundwater sources used for the MPWSP.

In August 2016, Trussell Technologies prepared a short technical memorandum and presented an initial analysis of carbon dioxide releases from the water sources used for the MPWSP to several members of the State Water Resources Control Board (SWRCB), the National Oceanic and Atmospheric Administration (NOAA), and ESA. Trussell Technologies was asked to prepare an additional technical memorandum detailing the assumptions and methods used to estimate carbon dioxide releases.

2 BACKGROUND

Mr. Bourcier used data contained in the April 2015 DEIR to estimate the amount of carbon dioxide that would be released when the water equilibrates with the atmosphere. Using data from

the exploratory boreholes (GeoScience 2014a), Mr. Bourcier estimated that between 822 and 14,877 tons of carbon dioxide could be released per year. Mr. Bourcier expressed his concerns regarding the potential for GHG releases from the source water used for the MPWSP, and suggested that an analysis of the GHG potential from source water be included in the DEIR.

To address Mr. Bourcier’s comment, we performed an analysis of the potential for carbon dioxide releases from the source water for the planned desalination plant. This technical memorandum provides details about the methods used in the analysis including calculations and assumptions.

To estimate carbon dioxide releases, we took several steps and made several assumptions including (1) flow path assumptions, (2) source water assumptions, (3) reverse osmosis (RO) modeling assumptions, and finally (4) equilibrium calculations. Each of these steps and assumptions is detailed in this technical memorandum.

3 FLOW PATH ASSUMPTIONS

In his comment, Mr. Bourcier mentioned that the potential carbon dioxide release can be calculated “assuming the feed water eventually equilibrates with the atmosphere.” Carbon dioxide will be released to the atmosphere if the concentration of carbon dioxide in the water (CO_{2(aq)}) is proportionally larger than the partial pressure of carbon dioxide (P_{CO₂}) in the atmosphere as defined by the Henry’s Law constant for carbon dioxide (K_H). This will only occur when the water is allowed to equilibrate with the atmosphere.

$$K_H = \frac{P_{CO_2}}{[CO_2(aq)]}$$

However, the source water for the MPWSP would not contact the atmosphere until after the water has passed through the desalination plant. The feedwater would be extracted through slant wells and conveyed to the desalination plant in an enclosed pipe. The water would then travel through the desalination plant. While the filtered water tanks prior to the reverse osmosis system allow for the water to contact the atmosphere, but there will not be enough residence time or mixing for the water to equilibrate with the atmosphere at that time and the mass transfer in these tanks will be insignificant. After the plant, the water would either contact the atmosphere (1) as finished water in the finished water tanks, or (2) as concentrate at the storage reservoir or the Monterey Regional Water Pollution Control Agency (MRWPCA) outfall. Figure 1 shows the process flow diagram for the MPWSP.

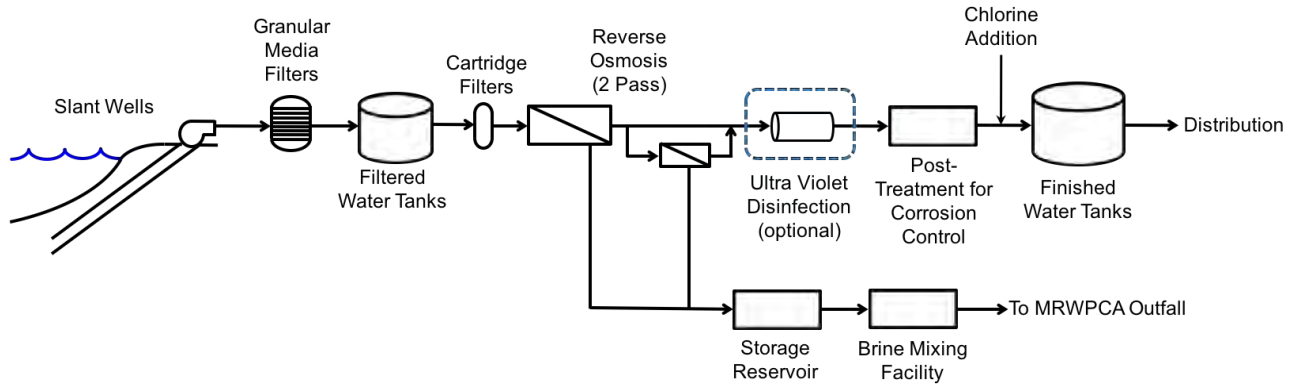

Figure 1 Process Flow Diagram of MPWSP

The water in the finished water tanks would travel through each treatment process prior to equilibration with the atmosphere. During post-treatment, the pH of the desalinated water would be adjusted to ensure that carbon dioxide would not be released from the desalinated water as it contacts the atmosphere. However, the concentrate from the RO process would not undergo any additional treatment or pH adjustment and would be released back to the ocean, at which point, it would equilibrate with the atmosphere and may release carbon dioxide. Therefore, to determine the amount of carbon dioxide that would be released from the MPWSP, we determined the amount of carbon dioxide in the RO concentrate as it is produced relative to the levels when the concentrate is at equilibrium with the carbon dioxide in the atmosphere.

4 SOURCE WATER ASSUMPTIONS

It is difficult to predict the future water quality of the source water with precision as the MPWSP will not be constructed for several years. Yet, the water quality of the source water impacts the concentration of carbon dioxide in the RO concentrate. To account for uncertainties in the source water quality, we considered two potential source waters that are representative of a “worst-case” and a “best-case” source water. The “worst-case” source water is water that is currently being drawn through a test slant well. The “best-case” source water is fresh seawater from the Monterey Bay.

A test slant well is currently operating at the CEMEX site. The location of the test slant well is shown in Figure 2. This test slant well is expected to be representative of the slant wells that will feed the MPWSP. The slant wells for the MPWSP are projected to pull 93 percent seawater from the Monterey Bay and 7 percent groundwater from the surrounding area when the MPWSP is operating (GeoScience 2014b). However, the test slant well only began operating in April 2015 and has not been running continuously. Hydrogeologists have modeled the groundwater and shown that it could take several years for the slant well to begin to draw fresh seawater because the fresh seawater must flush out any old intruded seawater in the flow path. (Figure 3).



Figure 2 Test Slant Well Location, Marina, CA.

If the test slant well pulled fresh seawater (that is already at equilibrium with the atmosphere), there would be minimal change in pH and carbon dioxide concentration as the water traveled through the ground, to the slant well, and into the desalination plant. Therefore, fresh seawater from the Monterey Bay is considered the “best-case” water quality for this analysis because it represents the scenario where the water quality would not change as it is drawn through the slant well.

In contrast, the test slant well water is considered the “worst-case” water because the seawater it is drawing is not fresh. Figure 3 shows that it could take up to four years for the slant well to be drawing 96% seawater, and the well has only been operating intermittently since April 2015. Currently, it is drawing old intruded seawater with a lower pH and higher silica concentration than seawater and would result in the release of more carbon dioxide.

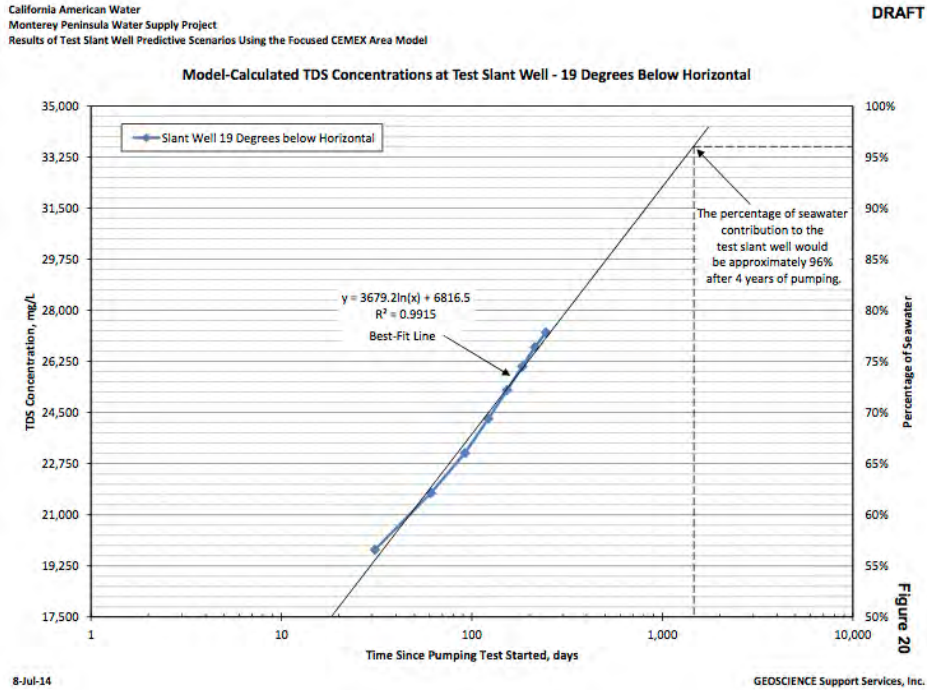

Figure 3 Time for Slant Well to Pull 96% Seawater (GeoScience 2014b).

To estimate the concentration of carbon dioxide in the RO concentrate, we modeled the RO process using the water quality of the two source waters: (1) the “worst-case” test slant well water, and (2) the “best-case” seawater.

4.1 TEST SLANT WELL WATER QUALITY

The water quality data from the test slant well was collected by GeoScience for California American Water (CalAm). Data that was used to perform the RO modeling is provided in Table 1 (GeoScience 2016). Sampling data from September 2016 was used because it was the most recent data available at the time of the analysis. By the end of September 2016, the test slant well had been operating continuously for 5 months and intermittently since April 2015. GeoScience sampled from the test slant well five times in September 2016. The water quality parameters of interest are the parameters that are input into the RO modeling software. Any non-detect (ND) values were set at the method detection limit (MDL). The average value from the five sampling events in September 2016 are shown in Table 1 and were input into the RO modeling software for analysis.

**Table 1 Test Slant Well Water Quality Data from GeoScience**

Constituent	Units	September 2016*
Temperature	°C	16.1
pH	-	7.08
Calcium	mg/L	472
Magnesium	mg/L	1,052
Sodium	mg/L	8,914
Potassium	mg/L	274
Ammonia (NH ₄ ⁺)	mg/L	0.03
Barium	µg/L	0.071
Strontium	µg/L	7,440
Bicarbonate	mg/L	142
Sulfate	mg/L	2,339
Chloride	mg/L	16,406
Fluoride	mg/L	0.94
Nitrate	mg/L	4.20
Phosphate	mg/L	0.10
Silica	mg/L	12.4
Boron	mg/L	3.24

*Average of the 5 sampling events during September 2016

4.2 SEAWATER QUALITY

To evaluate the “best-case” scenario, we used existing seawater data from the Monterey Bay area. These data are found in the appendices of the MPWSP Request for Proposals (RFP) released by CalAm in 2013 (California American Water 2013). The raw water quality conditions for the basis of design of the proposed desalination plant were assumed to be representative of the seawater in the area. The raw water quality data reported in the MPWSP RFP was determined from the compilation of data from several projects in the area including the Moss Landing Desalination Pilot Study (MWH 2010), the Santa Cruz/Soquel Creek Desalination Pilot Study (CDM 2010), and the Santa Cruz/Soquel Creek Watershed Sanitary Survey (Archibald Consulting, Palencia Consulting Engineers et al. 2010).

The data is shown in Table 2. The MPWSP RFP did not include values for ammonia and nitrate. However, these values were determined from the same dataset used to produce the RFP.

**Table 2 Seawater Quality Data**

Constituent	Units	Average Values*
Temperature	°C	12
pH	-	8
Calcium	mg/L	405
Magnesium	mg/L	1,262
Sodium	mg/L	10,604
Potassium	mg/L	392
Ammonia (NH ₄ ⁺)	mg/L	1.29
Barium	mg/L	0.013
Strontium	mg/L	7.81
Bicarbonate	mg/L	105
Sulfate	mg/L	2,667
Chloride	mg/L	19,030
Fluoride	mg/L	1.28
Nitrate	mg/L	0.89
Phosphate	mg/L	1.7
Silica	mg/L	1.3
Boron	mg/L	5

*Values are based on the central tendency observed from three projects in the area (Archibald Consulting, Palencia Consulting Engineers et al. 2010, CDM 2010, MWH 2010).

5 RO MODELING

All RO modeling was performed using IMSDesign-2016 by Hydranautics. The integrated membrane solutions design software is a free software that can be downloaded from the Hydranautics website (Hydranautics 2016). The software allows for many different configurations and assumptions. For the purposes of this analysis, the RO software was set up to replicate the design of the RO process planned for the MPWSP.

5.1 RO MODELING ASSUMPTIONS

The RO system configuration consists of a first pass seawater RO (SWRO) system followed by a 40% partial second pass brackish water RO system (BWRO) (CDM 2014). The first pass recovery is 45% followed by a second pass recovery of 90% resulting in an overall recovery of 41%. Additional design parameters that were modeled are shown in Table 3. Figure 4 shows the configuration of the modeled RO process.

**Table 3 RO Process Design and Modeled Assumptions**

RO Configuration		
Well-type	Sea Well conventional	
No. of Passes	2	
Overall Recovery	41	%
First Pass SWRO		
Permeate Flow/train	1.44	mgd/train
Recovery	42.5	%
Maximum Membrane Flux	8.75	gfd
Maximum Feed Pressure	1000	psi
Elements per Vessel	7	
Element Type	SWC5	
No. of Pressure Vessels	70	
Membrane Age	5	yr
Flux Decline	5	%/yr
Fouling Factor	0.774	
Salt Passage Increase	7	%/yr
Second Pass BWRO		
Maximum Capacity/Train	0.52	mgd/train
Minimum Percent of Total First Pass Permeate to Second Pass Feed	40	%
No. of BWRO Stages Per Train	2	
Recovery	90	%
Maximum Membrane Flux	18	gfd
Maximum Feed Pressure	230	psi
Elements per vessel	7	
Element Type	ESPA2	
No. of Pressure Vessels	8	
Maximum pH	10	
Membrane Age	5	yr
Flux Decline	3	%/yr
Fouling Factor	0.859	
Salt Passage Increase	5	%/yr
Energy Recovery Device		
Type of Energy Recovery Device	Pressure/Work Exchanger	
Leakage	1	%
Volumetric Mixing	3	%
H.P. Differential	7.25	psi

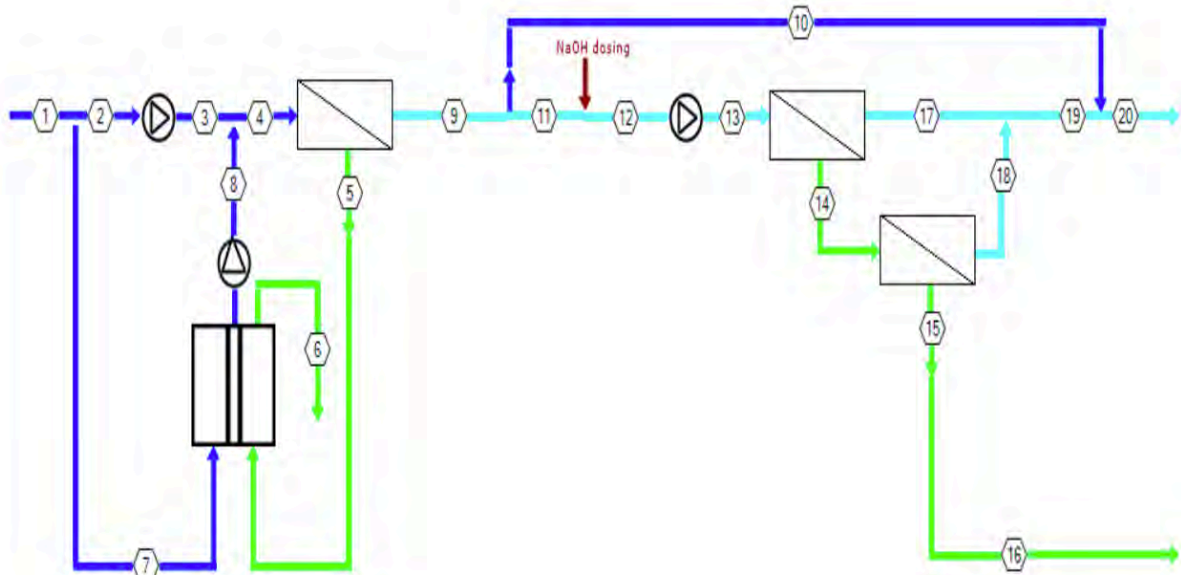

Figure 4 Screenshot of the RO Configuration Modeled Using the IMSDesign-2016 Software by Hydranautics

The RO modeling software allows for the input of the water quality parameters listed in Table 1 and Table 2 as shown in the screenshot of the software in Figure 5. The software produces an output of water quality parameters for the raw water, blended water, feed water, permeate water, concentrate, and the Energy Recovery Device (ERD) reject. A printout of one set of results is provided in Appendix A.

Project: FreshSW Calculated by: Anya Kaufmann Temperature: 120 °C Water Type: Sea Well Conventional Date: 10/11/2016

pH: 8.00 CO3: 6-714 mg/l CO2: 0.715 mg/l E Conductivity: 53775.9 us/cm

Cations		Anions	
mg/l	mg/l CaCO3	mg/l	mg/l CaCO3
Ca	405.00	HCO3	105.00
Mg	1262.00	SO4	2667.00
Na	10604.00	Cl	19030.00
K	392.00	F	1.28
NH4	1.29	NO3	0.89
Ba	0.013	PO4	1.70
Sr	7.810	SiO2	1.30
		B	5.00
Total_msa/l	593.01	Total_msa/l	294.46

Saturations

Calculated TDS	24491 mg/l	CaSO4	23.1 %
Osmotic pressure	349.5 BSI	BaSO4	52.1 %
Ca3(PO4)2 SI	0.61	SrSO4	27.7 %
CCRP	19.99 mg/l	CaF2	28.4 %
		Silica	1.2 %

Nitto HYDRANAUTICS Nitto Group Company

Figure 5 Example RO Model Input Parameters Screenshot

5.2 RO MODELING RESULTS

For this analysis, the parameters of interest from the RO modeling are the pH, bicarbonate, carbonate, and total dissolved solids of the RO concentrate. Using pH, bicarbonate, and carbonate, the alkalinity of the RO concentrate was calculated, using the typical assumption in seawater that the carbonate species are the predominate acid buffering constituents.

$$Alkalinity \left(\frac{meq}{L} \right) = \left[\frac{HCO_3^- \left(\frac{mg}{L} \right)}{61 \left(\frac{mg}{mmol} \right)} \right] + 2 \left[\frac{CO_3^{2-} \left(\frac{mg}{L} \right)}{60 \left(\frac{mg}{mmol} \right)} \right] + \left[10^{-(pK_w^* - pH)} * 1000 \left(\frac{mmol}{mol} \right) \right] - \left[10^{-pH} * 1000 \left(\frac{mmol}{mol} \right) \right]$$

$$Alkalinity \left(\frac{mg}{L} \text{ as } CaCO_3 \right) = Alkalinity \left(\frac{meq}{L} \right) \times 50 \left(\frac{mg \text{ } CaCO_3}{meq} \right)$$

The results from the RO Modeling, and the subsequent alkalinity calculation, are shown in Table 4.

Table 4 Modeled RO Concentrate Water Quality Parameters

Constituent	Test Slant Well (RO Concentrate)	Seawater (RO Concentrate)
Temperature (°C)	16.1	12
pH	7.25	8.17
Bicarbonate (mg/L)	244	166
Carbonate (mg/L)	4.7	31
TDS (mg/L)	52,052	60,614
Alkalinity (mg/L as CaCO ₃)	207.8	187.9

Using the parameters shown in Table 4, we calculated the expected amount of carbon dioxide released for each source water.

6 ESTIMATING CARBON DIOXIDE RELEASED

There are many relationships between the species of carbon dioxide in seawater. Using temperature and salinity corrected equilibrium constants K_0 , K_1^* , K_2^* , K_w^* , pH, and alkalinity, we determined the total carbon in a sample of water, assuming the carbonate species are the predominate pH buffering species. The equilibrium constants are dependent on the salinity and temperature of the water, and we corrected the equilibrium constants using data from literature.

6.1 CALCULATING TOTAL CARBON

The total carbon (C_T) in a sample of water is defined as the sum of the concentrations of carbon dioxide, bicarbonate, and carbonate in the water.

$$C_T = [CO_2] + [HCO_3^-] + [CO_3^{2-}]$$

Where carbon dioxide in water is often written as $[H_2CO_3^*]$ and it takes two forms, (1) carbonic acid $[H_2CO_3]$, and (2) aqueous carbon dioxide $[CO_{2(aq)}]$.

$$[CO_2] = [H_2CO_3^*] = CO_{2(aq)} + [H_2CO_3]$$

Which results in the following form:

$$C_T = [H_2CO_3^*] + [HCO_3^-] + [CO_3^{2-}]$$

Using the definition of total carbon, alkalinity (A_T), the temperature and salinity corrected equilibrium constants, and pH, C_T of the RO concentrate can be calculated. The pH was adjusted for the appropriate scale assumed by the equilibrium constants.

$$K_0 = \frac{[H_2CO_3^*]}{p(CO_2)}; K_1^* = \frac{[H^+][HCO_3^-]}{[H_2CO_3^*]}; K_2^* = \frac{[H^+][CO_3^{2-}]}{[HCO_3^-]}; K_W^* = [H^+][OH^-]$$

$$A_T = [HCO_3^-] + 2[CO_3^{2-}] + [OH^-] - [H^+]$$

We compared the calculated C_T of the RO concentrate to the anticipated C_T of the RO concentrate at equilibrium with the atmosphere to estimate the amount of carbon dioxide that would be released from the RO concentrate. We determined the C_T of the RO concentrate at equilibrium with the atmosphere by iteratively varying the pH until the carbon dioxide concentration was in equilibrium with the atmosphere.

The difference between the calculated C_T of the RO concentrate and the anticipated C_T of the RO concentrate at equilibrium is the amount of carbon dioxide that will be released.

There are several important considerations when performing these calculations. First, the equilibrium constants are dependent on temperature and salinity. Corrections to the equilibrium constants at standard conditions must be incorporated to reflect the true temperature and salinity of the samples. Second, the concentration of carbon dioxide in the atmosphere must be determined.

The methods for correcting the equilibrium constants and determining the concentration of carbon dioxide in the atmosphere are discussed below.

6.2 EQUILIBRIUM CONSTANT CORRECTIONS

The equilibrium constants of the carbonic species are defined at a standard temperature of 25°C and a salinity of 35 PSS. However, the RO concentrates of both the test slant well samples and the fresh seawater have non-standard temperatures and salinity.

6.2.1 Determining Salinity

The temperature of the water is known; however, the salinity of the water must be determined. The RO model reported the total dissolved solids (TDS) of the RO concentrate. Using TDS, we calculated the salinity of the RO concentrate.

The major seawater ions can be calculated from salinity because it is known that the proportions of major ion constituents in seawater are relatively constant (Stumm and Morgan 1981). Conceptually, salinity is a measure of the mass of dissolved inorganic matter in a given mass of seawater. The constant proportions of ions in seawater around the globe has been observed and documented by researchers as far back as 1779 by Bergman, and then in 1884 by Dittmar, among others (Millero 2006). These proportions have been reassessed over time, with only very slight changes made. Ion proportions representative of “average” seawater, which are consistent but not identical to ratios measured by Dittmar, are reported by Millero (2006) and are shown in Table 5, below. In Table 5, the second column reports “g/Cl” which is the mass of the ion species in grams per kilogram of seawater as a function of chlorinity (also in g/kg). These ratios are the basis for the calculation of major ion concentrations from measured salinity values.

Millero (2006) also provides the relationship between chlorinity and salinity as being:

$$S (\text{‰}) = 1.80655 \times Cl (\text{‰}).$$

Knowing the chlorinity as a function of salinity, and the mass of each ion species as a function of chlorinity, the mass (g/kg) of each of the major ion constituents in seawater was calculated. The ion concentration as g/kg was converted to mg/L by multiplying by the density of seawater (approximately 1.025). Millero and Sohn (1992) provide an equation that relates density to the Practical Salinity Scale (PSS), which was used in converting ion concentration in g/kg to mg/L.

Table 5 Ion Ratios in "Average" Seawater as a Function of Chlorinity (Millero 2006)

Composition of 1 kg of Natural Seawater as a Function of Chlorinity ^a					
Species	g/Cl	M _i	n _i /Cl	e _i /Cl	n _i Z _i ² /Cl
Na ⁺	0.556614	22.9898	0.024211	0.024211	0.024211
Mg ²⁺	0.066260	24.3050	0.002726	0.005452	0.010905
Ca ²⁺	0.021270	40.0780	0.000531	0.001061	0.002123
K ⁺	0.020600	39.0983	0.000527	0.000527	0.000527
Sr ²⁺	0.000410	87.6200	0.000005	0.000009	0.000018
Cl ⁻	0.998910	35.4527	0.028176	0.028176	0.028176
SO ₄ ²⁻	0.140000	96.0636	0.001457	0.002915	0.005830
HCO ₃ ⁻	0.005524	61.0171	0.000091	0.000091	0.000091
Br ⁻	0.003470	79.9040	0.000043	0.000043	0.000043
CO ₃ ²⁻	0.000830	60.0092	0.000014	0.000028	0.000055
B(OH) ₄ ⁻	0.000407	78.8404	0.000005	0.000005	0.000005
F ⁻	0.000067	18.9984	0.000004	0.000004	0.000004
OH ⁻	0.000007	17.0034	0.0000004	0.0000004	0.0000004
1/2 Σ =	1.814369		0.028895	0.031261	0.035994
B(OH) ₃	0.000996	61.8322	0.000016	0.000016	
Σ =	1.815362		0.028911	0.031277	

^a For average seawater S = 35, Cl = 19.374, pH_{SWS} = 8.1, TA = 2.400 mmol kg⁻¹, and t = 25°C.

Using the ion concentrations and the relationship between salinity and chlorinity, the salinity of the water was calculated from the TDS. The salinity of each of the RO concentrates is shown below in Table 6.

Table 6 Salinity Values of the RO Concentrate Calculated from TDS

Constituent	Test Slant Well (RO Concentrate)	Seawater (RO Concentrate)
TDS (mg/L)	52,052	60,614
Salinity (PSS)	48.7	56.7

6.2.2 Temperature and Salinity Corrections

Once salinity of the RO concentrate was determined, the equilibrium constants were corrected according to the temperature and salinity of the sample water.

K₀ was corrected for temperature (T, °K) and salinity (S) using the equation derived by Weiss (1974) and the corresponding constants shown in Table 7.

$$\ln K_0 = A_1 + A_2 \frac{100}{T} + A_3 \ln \left(\frac{T}{100} \right) + S \left[B_1 + B_2 \frac{T}{100} + B_3 \left(\frac{T}{100} \right)^2 \right]$$

Table 7 Constants for the calculation of K₀

Constant	Value (moles/kg*atm)
A ₁	-60.2409
A ₂	93.4517
A ₃	23.3585
B ₁	0.023517
B ₂	-0.023656
B ₃	0.00474036

Millero, Pierrot et al. (2002) compared different laboratory measurements of the equilibrium constants K₁ and K₂ at different temperatures and salinities. Using the relationships developed by Millero, Pierrot et al. (2002), K₁ and K₂ were determined for the appropriate temperature (T, °K) and salinity (S).

$$pK_1^* = -8.712 - 9.460 \times 10^{-3}S + 8.56 \times 10^{-5}S^2 + \frac{1355.1}{T} + 1.7979 \ln(T)$$

$$pK_2^* = 17.0001 - 0.01259S - 7.9334 \times 10^{-5}S^2 + \frac{936.291}{T} - 1.87354 \ln(T) - 2.61471 \frac{S}{T} + 0.07479 \frac{S^2}{T}$$

K_w was corrected for temperature (T, °K) and salinity (S) using constants and relationships defined by Harned and Owen (1958) and Millero (2013).

$$\log K_w = -\frac{4470.99}{T} + 6.0875 - 0.017060T$$

$$\ln K_w = \ln(10) \times \log K_w$$

$$\ln K_w^* = \ln K_w + 0.37201\sqrt{S} - 0.0162 S$$

6.3 ATMOSPHERIC CARBON DIOXIDE

The concentration of carbon dioxide in the atmosphere is an important parameter of this analysis. The concentration of carbon dioxide in the atmosphere is measured daily at the Mauna Loa Observatory in Hawaii. Charles David Keeling of the Scripps Institution of Oceanography began taking carbon dioxide measurements in 1956, and there is a near continuous record of carbon dioxide in the atmosphere since 1958. The data is called the Keeling Curve. The average concentration of carbon dioxide in the atmosphere in 2016 was determined by plotting annual averages of carbon dioxide and extrapolating (Figure 6). From this analysis, the anticipated average concentration of carbon dioxide in the atmosphere in 2016 is 402 ppm.

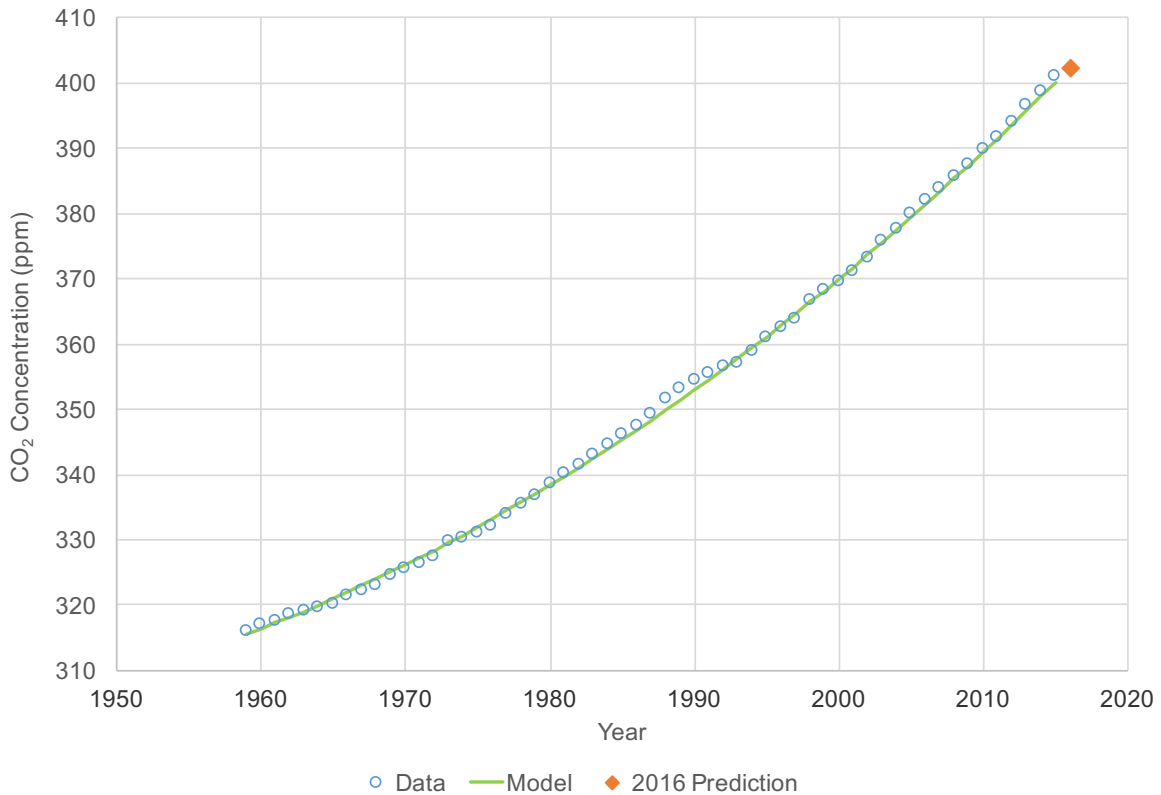

Figure 6 Annual Average Carbon Dioxide Concentrations (Tans and Keeling 2016)

6.4 CALCULATING CARBON DIOXIDE IN RO CONCENTRATE

Once the equilibrium constants were corrected for temperature and salinity, release of carbon dioxide from the RO concentrate was estimated. The difference between the calculated C_T of the RO concentrate and the C_T of the RO concentrate estimated at equilibrium with the atmosphere

yielded the concentration of carbon dioxide released. Using the expected recovery and capacity of the desalination plant, we calculated the rate of concentrate production. The MPWSP is a 9.6 mgd desalination facility with 41% percent overall recovery. This yielded a concentrate production of 14 mgd.

$$Q_{concentrate} = \frac{Q_{permeate}}{\%recovery} - Q_{permeate}$$

The total mass of carbon dioxide released is calculated using the concentrate production and the concentration of carbon dioxide released. Results are discussed in the following section.

6.5 RESULTS

The results of the analysis are shown in Table 8. The test slant well water source is projected to produce 735 metric tons of carbon dioxide per year. A fresh seawater source is projected to produce 95 metric tons of carbon dioxide per year.

Table 8 Carbon dioxide released from MPWSP with different source waters

Result	Test Slant Well	Seawater
CO ₂ (metric tons/yr)	735	95

7 CONCLUSIONS

To estimate carbon dioxide release from the source water for the MPWSP we looked at the flow path through the desalination plant, made assumptions about the source water, modeled the RO process, and used relationships among carbonic species. Through our analysis, we determined that the RO concentrate is the only water in the process that may release CO₂ as it comes to equilibrium with the atmosphere. We used RO modeling software to estimate the water quality of the RO concentrate, and we performed this analysis using different source water assumptions.

The analysis looked at “worst-case” and “best-case” source water qualities. The “worst-case” water quality was the quality in the current test slant well water because it has a lower pH and higher alkalinity than seawater and is expected to be worse than the water quality the MPWSP would actually use as source water. The water being drawn from the slant well is expected to become more representative of seawater as it continues to be pumped; however, at the present time, evidence suggests the slant well is still drawing old intruded seawater. The amount of carbon dioxide projected to be released from the MPWSP if the current test slant well water is used as the water source would be 735 metric tons per year.

The “best-case” water quality for this analysis was fresh seawater because, ultimately, there should be minimal change in pH and alkalinity as the water travels through the ground, to the slant well, and into the desalination plant. If fresh seawater is the source water for the MPWSP, the projected amount of carbon dioxide released would be 95 metric tons per year. Even in the best-case scenario there would be carbon dioxide released because of the RO process. The water



would be concentrated as it travels through the RO membranes and the concentrate would eventually equilibrate with the atmosphere.

Mr. Bourcier estimated that 822 to 14,577 metric tons of carbon dioxide would be released if the exploratory boreholes cited in the DEIR are the source water for the MPWSP. However, this analysis shows that the projected range of released carbon dioxide would be 95 to 735 metric tons per year.

8 REFERENCES

- Archibald Consulting, Palencia Consulting Engineers and Starr Consulting (2010). Proposed scwd2 Desalination Project Watershed Sanitary Survey.
- California American Water (2013). Monterey Peninsula Water Supply Project Desalination Infrastructure Request for Proposals.
- CDM (2010). Seawater Reverse Osmosis Desalination Pilot Test Program Report.
- CDM (2014). California American Water 60% Overall Submittal Technical Specifications for Monterey Peninsula Water Supply Project Desalination Infrastructure.
- GeoScience (2014a). April 2015 DEIR Appendix C3 - Summary of Results: Exploratory Boreholes.
- GeoScience (2014b). April 2015 DEIR Appendix E1 - Results of test slant well predictive scenarios using the CEMEX Area Model.
- GeoScience (2016). Monterey Peninsula Water Supply Project Test Slant Well Long Term Pumping Monitoring Report No. 74.
- Harned, H. S. and B. B. Owen (1958). The Physical Chemistry of Electrolytic Solutions. New York, Reinhold Publishing Corporation.
- Hydranautics. (2016). "IMS-Design Software." from <http://membranes.com/solutions/software/>.
- Millero, F. J. (2006). Chemical Oceanography. Boca Raton, Taylor & Francis Group, LLC (CRC Press).
- Millero, F. J. (2013). Chemical Oceanography. Boca Raton, Taylor & Francis Group, LLC (CRC Press).
- Millero, F. J., D. Pierrot, L. K., R. Wanninkhof, R. Feely, C. L. Sabine, R. M. Key and T. Takahashi (2002). "Dissociation constants for carbonic acid determined from field measurements." Deep Sea Research I(49): 1705-1723.
- Millero, F. J. and M. L. Sohn (1992). Chemical Oceanography. Boca Raton, CRC Press, Inc.
- MWH (2010). Coastal Water Project Pilot Plant Report.
- Stumm, W. and J. J. Morgan (1981). Aquatic Chemistry, An Introduction Emphasizing Chemical Equilibria in Natural Waters, John Wiley & Sons.
- Tans, P. and R. Keeling. (2016). from <http://www.esrl.noaa.gov/gmd/ccgg/trends/> and scrippsco2.ucsd.edu/.



Weiss, R. F. (1974). "Carbon dioxide in water and seawater: the solubility of non-ideal gas." Marine Chemistry **2**: 203-215.



APPENDIX A

RO Modeling Results Using August 2016 Slant Well Data

DRAFT

Two Pass With Inter-Pass Pump, Pressure/Work Exchanger, Partial

Project name	SlantWellWQ_Sep2016		Page : 1/5	
Calculated by	Anya Kaufmann		Permeate flow/train	1.440 0.520 mgd
HP Pump flow	1013.01	401.03 gpm	Total product flow	9.67 mgd
Feed pressure	669.5	171.8 psi	Number of trains	7
Feed temperature		16.2 °C(61.2°F)	Raw water flow/train	3.388 mgd
Feed water pH	7.08	10.00	P1 Permeate to P2 Feed	40.1 %
Chem dose, mg/l, - / 100 %	None	9.4 NaOH	Blended permeate flow	9.674 mgd
Leakage		1 %	Permeate recovery	42.50 90.00 %
Volumetric mixing		3 %	Total system recovery	40.8 %
H.P. differential		7.25 psi	Element age	5.0 5.0 years
Boost pressure		24.47 psi	Flux decline %, per year	5.0 3.0
Specific energy		1.10 kwh/kgal	Fouling factor	0.77 0.86
Pass NDP	252.4	144.8 psi	SP increase, per year	7.0 5.0 %
Average flux rate	7.35	15.5 gfd	Inter-stage pipe loss	3.0 psi

Feed type Sea Well Conventional

Pass - Stage	Perm. Flow	Flow / Vessel Feed Conc	Flux	DP	Flux	Beta	Stagewise Pressure			Perm.	Element	Element	PV# x
	gpm	gpm gpm	gfd	psi	gfd		Perm.	Boost	Conc	TDS	Type	Quantity	Elem #
					Max		psi	psi	psi	mg/l			
1-1	999.6	33.6 19.3	7.3	17.2	11.7	1.04	0	0	652.3	170.9	SWC5	490	70 x 7M
2-1	258	50.2 17.9	16.6	26.4	18.1	1.21	0	0	145.5	2.3	ESPA2	56	8 x 7M
2-2	103.4	35.8 10	13.3	15.1	14.6	1.29	0	0	127.3	8	ESPA2	28	4 x 7M

Ion (mg/l)	Raw Water	Blended Water	Feed Water	Permeate Water	Concentrate	ERD Reject
Hardness, as CaCO3	5491.48	5491.48	5562.79	4.936	9666.0	9540.79
Ca	472.00	472.00	478.13	0.424	830.8	820.04
Mg	1052.00	1052.00	1065.66	0.946	1851.7	1827.73
Na	8914.00	8914.00	9029.13	38.826	15653.3	15451.10
K	274.00	274.00	277.53	1.494	480.8	474.59
NH4	0.03	0.03	0.03	0.000	0.1	0.05
Ba	0.000	0.000	0.000	0.000	0.0	0.00
Sr	7.440	7.440	7.537	0.007	13.1	12.93
H	0.00	0.00	0.00	0.002	0.0	0.00
CO3	1.14	1.14	1.20	0.001	4.7	4.61
HCO3	142.00	142.00	143.74	0.993	244.1	241.06
SO4	2339.00	2339.00	2369.37	2.205	4117.0	4063.62
Cl	16406.00	16406.00	16618.08	62.404	28820.4	28448.02
F	0.94	0.94	0.95	0.007	1.6	1.63
NO3	4.20	4.20	4.25	0.128	7.3	7.16
PO4	0.10	0.10	0.10	0.000	0.2	0.17
OH	0.00	0.00	0.00	0.020	0.0	0.01
SiO2	12.40	12.40	12.56	0.036	21.8	21.51
B	3.24	3.24	3.27	0.586	5.1	5.03
CO2	7.62	7.62	7.62	4.75	7.62	7.62
TDS	29628.49	29628.49	30011.55	108.08	52051.94	51379.26
pH	7.08	7.08	7.08	5.57	7.25	7.25

Saturations	Raw Water	Feed Water	Concentrate	Limits
CaSO4 / ksp * 100, %	25	26	51	400
SrSO4 / ksp * 100, %	25	25	50	1200
BaSO4 / ksp * 100, %	0	0	0	10000
SiO2 saturation, %	12	12	20	140
CaF2 / ksp * 100, %	17	18	118	50000
Ca3(PO4)2 saturation index	-1.3	-1.3	-0.5	2.4
CCPP, mg/l	17.93	18.82	86.50	100000
Ionic strength	0.59	0.60	1.04	
Osmotic pressure, psi	302.9	306.9	532.1	

Product performance calculations are based on nominal element performance when operated on a feed water of acceptable quality. The results shown on the printouts produced by this program are estimates of product performance. No guarantee of product or system performance is expressed or implied unless provided in a separate warranty statement signed by an authorized Hydranautics representative. Calculations for chemical consumption are provided for convenience and are based on various assumptions concerning water quality and composition. As the actual amount of chemical needed for pH adjustment is feedwater dependent and not membrane dependent, Hydranautics does not warrant chemical consumption. If a product or system warranty is required, please contact your Hydranautics representative. Non-standard or extended warranties may result in different pricing than previously quoted. Version : 1.216.73 %

Two Pass With Inter-Pass Pump, Pressure/Work Exchanger, Partial

Project name	SlantWellWQ_Sep2016				Page : 2/5
Calculated by	Anya Kaufmann		Permeate flow/train	1.440	0.520 mgd
HP Pump flow	1013.01	401.03 gpm	Total product flow		9.67 mgd
Feed pressure	669.5	171.8 psi	Number of trains		7
Feed temperature		16.2 °C(61.2°F)	Raw water flow/train	3.388	mgd
Feed water pH	7.08	10.00	P1 Permeate to P2 Feed		40.1 %
Chem dose, mg/l, - / 100 %	None	9.4 NaOH	Blended permeate flow		9.674 mgd
Leakage		1 %	Permeate recovery	42.50	90.00 %
Volumetric mixing		3 %	Total system recovery		40.8 %
H.P. differential		7.25 psi	Element age	5.0	5.0 years
Boost pressure		24.47 psi	Flux decline %, per year	5.0	3.0
Specific energy		1.10 kwh/kgal	Fouling factor	0.77	0.86
Pass NDP	252.4	144.8 psi	SP increase, per year	7.0	5.0 %
Average flux rate	7.35	15.5 gfd	Inter-stage pipe loss		3.0 psi

Pass -	Perm.	Flow / Vessel	Flux	DP	Flux	Beta	Stagewise Pressure			Perm.	Element	Element	PV# x	
													Elem #	
					Max									
Stage	Flow	Feed	Conc				Perm.	Boost	Conc	TDS	Type	Quantity		
	gpm	gpm	gpm	gfd	psi	gfd	psi	psi	psi	mg/l				
1-1	999.6	33.6	19.3	7.3	17.2	11.7	1.04	0	0	652.3	170.9	SWC5	490	70 x 7M
2-1	258	50.2	17.9	16.6	26.4	18.1	1.21	0	0	145.5	2.3	ESPA2	56	8 x 7M
2-2	103.4	35.8	10	13.3	15.1	14.6	1.29	0	0	127.3	8	ESPA2	28	4 x 7M

Pass -	Element	Feed	Pressure	Conc	NDP	Permeate	Permeate	Beta	Permeate (Passwise cumulative)				
Stage	No.	Pressure	Drop	Osmo.	psi	Flow	Flux	TDS	Ca	Mg	Na	Cl	
		psi	psi	psi	psi	gpm	gfd						
1-1	1	669.5	3.45	339.5	336	3.3	11.7	1.04	82.3	0.326	0.727	29.568	47.55
1-1	2	666	3	373.8	296.6	2.8	10.1	1.03	93.1	0.369	0.823	33.47	53.826
1-1	3	663	2.64	408.8	259.4	2.4	8.5	1.03	105.4	0.418	0.932	37.878	60.916
1-1	4	660.4	2.34	443.1	222.9	2	7.1	1.03	119.3	0.473	1.055	42.873	68.95
1-1	5	658.1	2.1	475.7	188.2	1.6	5.8	1.03	134.9	0.535	1.193	48.473	77.958
1-1	6	656	1.92	505.5	156.3	1.3	4.6	1.02	152.1	0.604	1.346	54.666	87.92
1-1	7	654.1	1.77	531.9	127.9	1	3.7	1.02	170.9	0.679	1.512	61.428	98.798
2-1	1	171.8	6.03	2.2	166.8	5	18.1	1.1	1.5	0.001	0.003	0.536	0.819
2-1	2	165.8	5.17	2.5	160.9	4.9	17.5	1.11	1.6	0.001	0.003	0.571	0.873
2-1	3	160.6	4.38	2.8	155.9	4.7	16.9	1.12	1.7	0.001	0.003	0.61	0.932
2-1	4	156.3	3.65	3.2	151.5	4.6	16.5	1.13	1.9	0.001	0.003	0.653	0.998
2-1	5	152.6	2.98	3.7	147.7	4.5	16	1.15	2	0.001	0.003	0.7	1.07
2-1	6	149.6	2.36	4.4	144.4	4.4	15.7	1.17	2.1	0.002	0.004	0.753	1.151
2-1	7	147.3	1.79	5.5	141.5	4.3	15.3	1.21	2.3	0.002	0.004	0.813	1.242
2-2	1	142.5	3.73	6.2	134.8	4.1	14.6	1.11	2.4	0.002	0.004	0.844	1.29
2-2	2	138.8	3.13	7.1	130.6	3.9	14.1	1.13	2.5	0.002	0.004	0.877	1.341
2-2	3	135.6	2.57	8.2	126.8	3.8	13.7	1.14	2.7	0.002	0.004	0.929	1.42
2-2	4	133.1	2.07	9.6	123.2	3.7	13.3	1.16	2.8	0.002	0.005	0.996	1.523
2-2	5	131	1.61	11.7	119.6	3.6	12.9	1.19	3.1	0.002	0.005	1.085	1.658
2-2	6	129.4	1.2	14.7	115.7	3.5	12.5	1.23	3.4	0.003	0.006	1.207	1.845
2-2	7	128.2	0.84	19.5	110.7	3.3	11.9	1.29	3.9	0.003	0.007	1.384	2.115

Product performance calculations are based on nominal element performance when operated on a feed water of acceptable quality. The results shown on the printouts produced by this program are estimates of product performance. No guarantee of product or system performance is expressed or implied unless provided in a separate warranty statement signed by an authorized Hydranautics representative. Calculations for chemical consumption are provided for convenience and are based on various assumptions concerning water quality and composition. As the actual amount of chemical needed for pH adjustment is feedwater dependent and not membrane dependent, Hydranautics does not warrant chemical consumption. If a product or system warranty is required, please contact your Hydranautics representative. Non-standard or extended warranties may result in different pricing than previously quoted. Version : 1.216.73 %

Two Pass With Inter-Pass Pump, Pressure/Work Exchanger, Partial [Pass 1]

Project name	SlantWellWQ_Sep2016			Permeate flow/train	1.440 mgd
Calculated by	Anya Kaufmann			Raw water flow/train	3.388 mgd
Feed flow	2352.78	gpm		Permeate recovery	42.50 %
Feed pressure	669.5	psi		Element age	5.0 years
Feed temperature	16.2	°C(61.2°F)		Flux decline %, per year	5.0
Feed water pH	7.08			Fouling factor	0.77
Chem dose, mg/l, -	None			SP increase, per year	7.0 %
Leakage	1	%			
Volumetric mixing	3	%			
H.P. differential	7.25	psi			
Boost pressure	24.47	psi			
Specific energy	6.44	kwh/kgal			
Pass NDP	252.4	psi			
Average flux rate	7.35	gfd			

Pass - Stage	Perm. Flow	Flow / Vessel		Flux	DP	NDP	Beta	Feed type			Perm. TDS	Element Type	Element Quantity	PV# x Elem #
		Feed	Conc					Stagewise Pressure	Boost	Conc				
	gpm	gpm	gpm	gfd	psi	gfd		psi	psi	psi	mg/l			
1-1	999.6	33.6	19.3	7.3	17.2	252.5	1.04	0.0	0.0	652.3	170.9	SWC5	490	70 x 7M

Ion (mg/l)	Raw Water	Feed Water	Permeate Water	Concentrate 1
Hardness, as CaCO3	5491.48	5562.79	7.895	9666.0
Ca	472.00	478.13	0.679	830.8
Mg	1052.00	1065.66	1.512	1851.7
Na	8914.00	9029.13	61.428	15653.3
K	274.00	277.53	2.359	480.8
NH4	0.03	0.03	0.000	0.1
Ba	0.000	0.000	0.000	0.0
Sr	7.440	7.537	0.011	13.1
H	0.00	0.00	0.003	0.0
CO3	1.14	1.20	0.000	4.7
HCO3	142.00	143.74	1.537	244.1
SO4	2339.00	2369.37	3.525	4117.0
Cl	16406.00	16618.08	98.798	28820.4
F	0.94	0.95	0.011	1.6
NO3	4.20	4.25	0.188	7.3
PO4	0.10	0.10	0.000	0.2
OH	0.00	0.00	0.000	0.0
SiO2	12.40	12.56	0.058	21.8
B	3.24	3.27	0.815	5.1
CO2	7.62	7.62	7.62	7.62
TDS	29628.49	30011.55	170.92	52051.94
pH	7.08	7.08	5.55	7.25

Saturations	Raw Water	Feed Water	Concentrate	Limits
CaSO4 / ksp * 100, %	25	26	51	400
SrSO4 / ksp * 100, %	25	25	50	1200
BaSO4 / ksp * 100, %	0	0	0	10000
SiO2 saturation, %	12	12	20	140
CaF2 / ksp * 100, %	17	18	118	50000
Ca3(PO4)2 saturation index	-1.3	-1.3	-0.5	2.4
CCPP, mg/l	17.93	18.82	86.50	100000
Ionic strength	0.59	0.60	1.04	
Osmotic pressure, psi	302.9	306.9	532.1	

Product performance calculations are based on nominal element performance when operated on a feed water of acceptable quality. The results shown on the printouts produced by this program are estimates of product performance. No guarantee of product or system performance is expressed or implied unless provided in a separate warranty statement signed by an authorized Hydranautics representative. Calculations for chemical consumption are provided for convenience and are based on various assumptions concerning water quality and composition. As the actual amount of chemical needed for pH adjustment is feedwater dependent and not membrane dependent, Hydranautics does not warrant chemical consumption. If a product or system warranty is required, please contact your Hydranautics representative. Non-standard or extended warranties may result in different pricing than previously quoted. Version : 1.216.73 %

Two Pass With Inter-Pass Pump, Pressure/Work Exchanger, Partial [Pass 2]

Project name	SlantWellWQ_Sep2016		Page : 4/5
Calculated by	Anya Kaufmann		
Feed flow	401.03 gpm	Permeate flow/train	0.520 mgd
Feed pressure	171.8 psi	Raw water flow/train	1.439 mgd
Feed temperature	16.2 °C(61.2°F)	Permeate recovery	90.00 %
Feed water pH	10.00	Element age	5.0 years
Chem dose, mg/l, 100 %	9.4 NaOH	Flux decline %, per year	3.0
Leakage	1 %	Fouling factor	0.86
Volumetric mixing	3 %	SP increase, per year	5.0 %
H.P. differential	7.25 psi	Inter-stage pipe loss	3.0 psi
Boost pressure	24.47 psi		
Specific energy	1.81 kwh/kgal		
Pass NDP	144.8 psi		
Average flux rate	15.5 gfd		

Pass - Stage	Perm. Flow gpm	Flow / Vessel Feed gpm	Conc gpm	Flux gfd	DP psi	NDP gfd	Beta	Feed type			Perm. TDS mg/l	Sea Well Conventional		PV# x Elem #
								Stagewise Pressure Perm. psi	Boost psi	Conc psi		Element Type	Element Quantity	
2-1	258.0	50.2	17.9	16.6	26.4	153.1	1.21	0.0	0.0	145.5	2.3	ESPA2	56	8 x 7M
2-2	103.4	35.8	10.0	13.3	15.1	123.6	1.29	0.0	0.0	127.4	8.0	ESPA2	28	4 x 7M

Ion (mg/l)	Raw Water	Feed Water	Permeate Water	Concentrate 1	Concentrate 2
Hardness, as CaCO3	7.89	7.89	0.034	22.1	79.1
Ca	0.68	0.68	0.003	1.9	6.8
Mg	1.51	1.51	0.007	4.2	15.2
Na	61.43	66.82	1.384	185.7	659.8
K	2.36	2.36	0.061	6.5	23.2
NH4	0.00	0.00	0.000	0.0	0.0
Ba	0.000	0.000	0.000	0.0	0.0
Sr	0.011	0.011	0.000	0.0	0.1
H	0.00	0.00	0.000	0.0	0.0
CO3	0.00	5.85	0.003	18.5	72.1
HCO3	1.54	2.34	0.090	4.1	8.1
SO4	3.53	3.53	0.019	9.9	35.3
Cl	98.80	98.80	2.115	274.5	975.0
F	0.01	0.01	0.000	0.0	0.1
NO3	0.19	0.19	0.028	0.5	1.6
PO4	0.00	0.00	0.000	0.0	0.0
OH	0.00	0.97	0.053	1.9	4.5
SiO2	0.06	0.06	0.000	0.2	0.6
B	0.82	0.82	0.207	2.0	6.3
CO2	7.62	0.00	0.00	0.00	0.00
TDS	170.92	183.93	3.97	509.97	1808.75
pH	5.55	10.00	8.80	11.71	11.46

Saturations	Raw Water	Feed Water	Concentrate	Limits
CaSO4 / ksp * 100, %	0	0	0	400
SrSO4 / ksp * 100, %	0	0	0	1200
BaSO4 / ksp * 100, %	0	0	0	10000
SiO2 saturation, %	0	0	0	140
CaF2 / ksp * 100, %	0	0	0	50000
Ca3(PO4)2 saturation index	-7.9	-2.2	0.6	2.4
CCPP, mg/l	-16.57	6.49	117.09	100000
Ionic strength	0.00	0.00	0.03	
Osmotic pressure, psi	1.8	2.0	19.3	

Product performance calculations are based on nominal element performance when operated on a feed water of acceptable quality. The results shown on the printouts produced by this program are estimates of product performance. No guarantee of product or system performance is expressed or implied unless provided in a separate warranty statement signed by an authorized Hydranautics representative. Calculations for chemical consumption are provided for convenience and are based on various assumptions concerning water quality and composition. As the actual amount of chemical needed for pH adjustment is feedwater dependent and not membrane dependent, Hydranautics does not warrant chemical consumption. If a product or system warranty is required, please contact your Hydranautics representative. Non-standard or extended warranties may result in different pricing than previously quoted. Version : 1.216.73 %

Two Pass With Inter-Pass Pump, Pressure/Work Exchanger, Partial

Project name : SlantWellWQ_Sep2016
 Temperature : 16.2 °C

Page : 5/5
 Element age, P1/P2 : 5.0/5.0 years

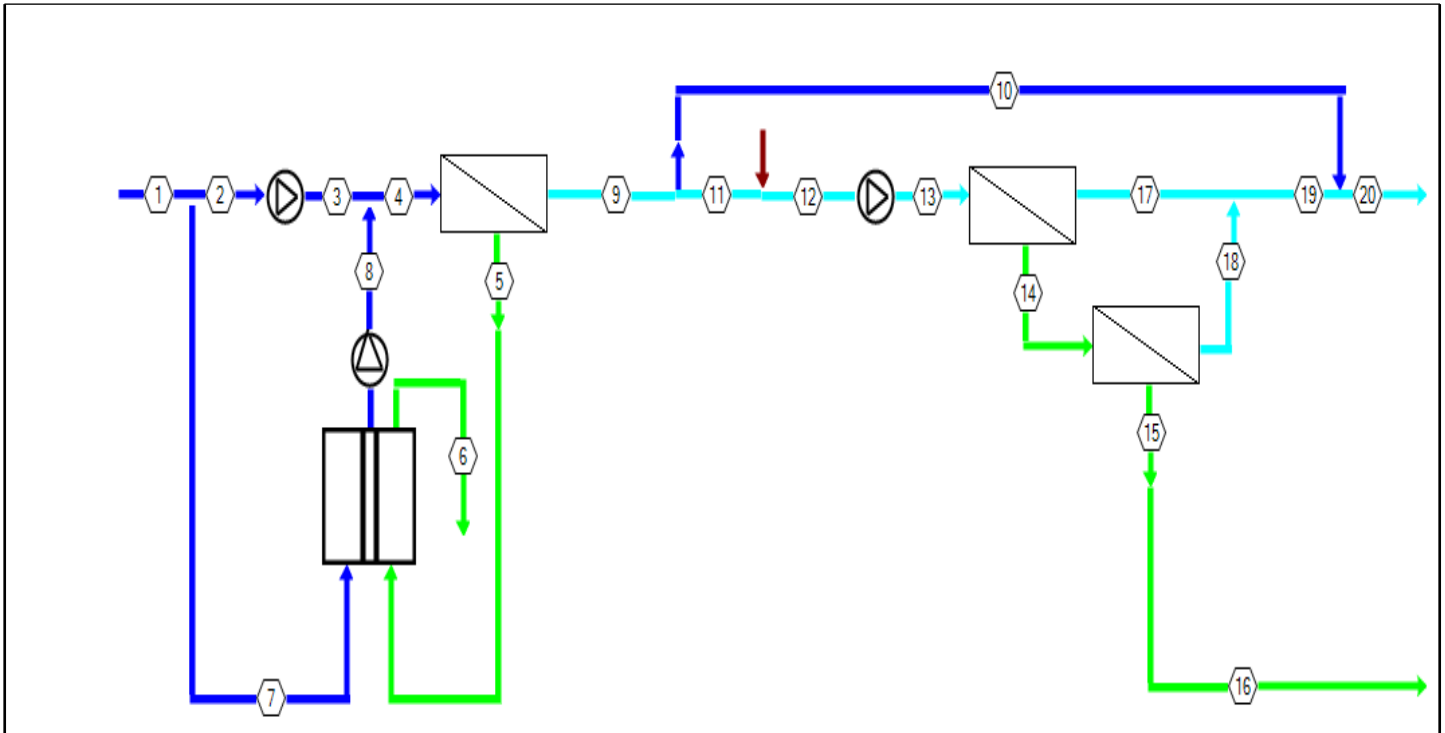

Stream No.	Flow (gpm)	Pressure (psi)	TDS	pH	B
1	2353	0	29628	7.08	3.24
2	1013	0	29628	7.08	3.24
3	1013	669	29628	7.08	3.24
4	2353	669	30012	7.08	3.27
5	1353	652	52052	7.25	5.09
6	1353	0	51379	7.25	5.03
7	1340	0	29628	7.08	3.24
8	1340	669	30301	7.08	3.30
9	1000	0	171	5.55	0.815
10	599	0	171	5.55	0.815
11	401	0	171	5.55	0.815
12	401	0	184	10.0	0.815
13	401	172	184	10.0	0.815
14	143	145	510	11.7	2.04
15	40.3	127	1809	11.5	6.33
16	40.3	0	1809	11.5	6.33
17	258	0	2.34	8.57	0.135
18	103	0	8.03	9.10	0.386
19	361	0	3.97	8.80	0.207
20	960	0	108	5.57	0.586

Product performance calculations are based on nominal element performance when operated on a feed water of acceptable quality. The results shown on the printouts produced by this program are estimates of product performance. No guarantee of product or system performance is expressed or implied unless provided in a separate warranty statement signed by an authorized Hydraulics representative. Calculations for chemical consumption are provided for convenience and are based on various assumptions concerning water quality and composition. As the actual amount of chemical needed for pH adjustment is feedwater dependent and not membrane dependent, Hydraulics does not warrant chemical consumption. If a product or system warranty is required, please contact your Hydraulics representative. Non-standard or extended warranties may result in different pricing than previously quoted. Version : 1.216.73 %